



Datenblatt - *Data sheet*

Abkantmaschine

Folding machine

FP30





Technische Daten - *Technical data*

Materialbreite max.	320 mm
max. material width	
Gewicht	10 kg
<i>Weight</i>	
Blechdicke	2,5 mm
<i>Sheet thickness</i>	<i>2.5 mm</i>
Abkanteleistung max. bei 90°	<i>max. folding capacity at 90°</i>
Alu / Kupfer - 300 x 2 mm	<i>Aluminium / Copper - 300 x 2 mm</i>
Stahlblech - 300 x 1 mm	<i>Steel sheet - 300 x 1 mm</i>
Abkantsegmente	150 , 75 , 50 , 25 mm
<i>Folding segments</i>	

Die Abkantmaschine wird im Schraubstock eingespannt.

The folding machine is clamped in a vise.

Tragen Sie Schutzhandschuhe, wenn Sie scharfkantige Teile verarbeiten.

Wear protective gloves when you handle sharp-edged parts.

Die Abkantmaschine ist keine Maschine im Sinne der Maschinenrichtlinie. Der Antrieb erfolgt mit Ihren eigenen Händen.

The folding machine is not a machine within the meaning of the Machinery Directive. The drive takes place with your own hands.



OPTIMUM

MASCHINEN - GERMANY

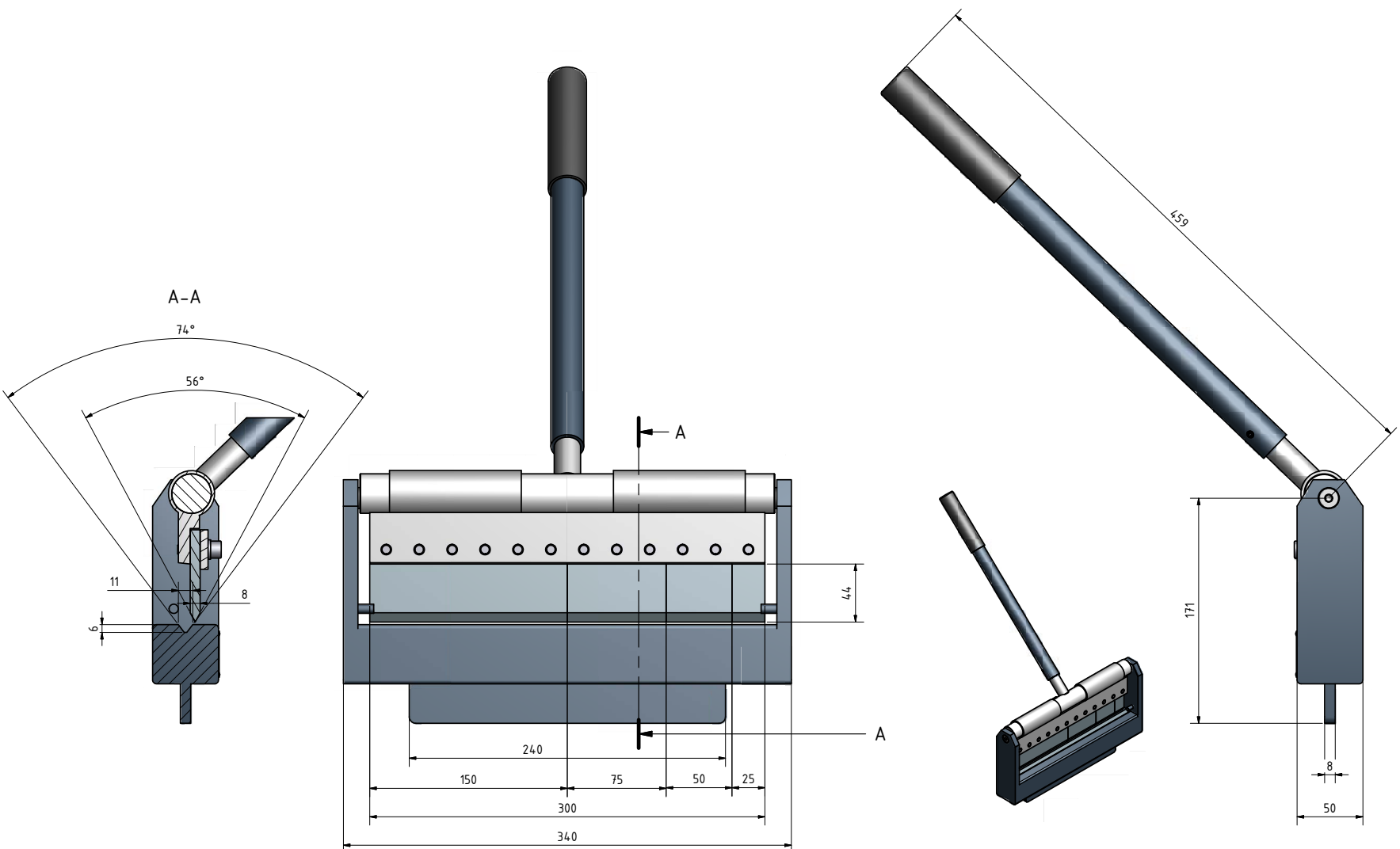

Originalbetriebsanleitung

FP30 DE | GB

OPTIMUM

MASCHINEN - GERMANY

Ersatzteile - Spare parts - FP 30

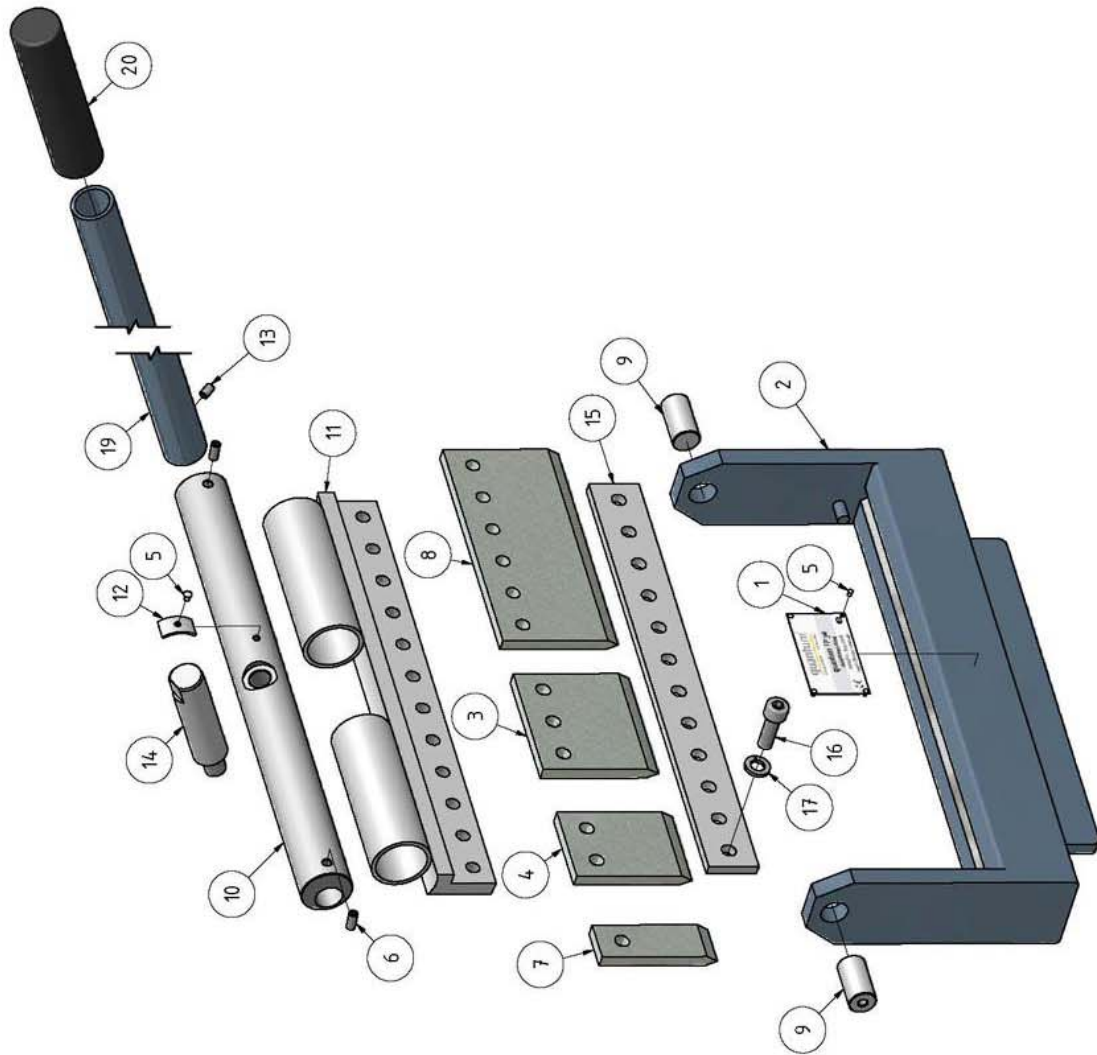

2-2: FP 30



Ersatzteilliste - Spare part list

Pos.	Bezeichnung	Designation	Menge	Grösse	Artikelnummer
			Qty.	Size	Item no.
1	Label	Label	1		0324402801
2	Rahmen	Frame	1		0324402802
3	Abkantsegment	Bending segment	1	75 mm	0324402803
4	Abkantsegment	Bending segment	1	50 mm	0324402804
5	Niet	Rivet	5		0324402805
6	Gewindestift	Grub screw	2	ISO 4026 - M5 x 12	
7	Abkantsegment	Bending segment	1	25 mm	0324402807
8	Abkantsegment	Bending segment	1	150 mm	0324402808
9	Exzenterlager	Eccentric bearing	2		0324402809
10	Exzenter	Eccentric	1		0324402810
11	Halter	Holder	1		0324402811
12	Anschlagstück	Limit block	1		0324402812
13	Gewindestift	Grub screw	1	ISO 4026 - M5 x 8	
14	Gewindebolzen	Thread bolt	1		0324402814
15	Klemmleiste	Clamping guide	1		0324402815
16	Innensechskantschraube	Hexagon socket screw	12	ISO 4762 - M8 x 25	
17	Federring	Spring ring	12	DIN 127 - A 8	
19	Hebelverlängerung	Lever extention	1		0324402819
20	Griff	Grip	1		0324402820

OPTIMUM

MASCHINEN - GERMANY

